

Part number
CAF 10



Brief description:

hoods for two levers, size "57.27", frontal entry, Pg16, metal version, IP66 (EN 60529) and IP69K (DIN 40050 - 9) degree of protection.

Product description	
Version	metal version
Series	hoods for two levers
Product type	with 4 pegs
Variant	frontal entry
Style	high construction
Family	CLASS enclosures
Size	size "57.27"
Technical data	
Material	metal
IP degree of protection	IP66 (and IP69K DIN 40050 - 9)
Cable entry	Pg16
Further technical details	
Weight	183,00 g

Approvals / Standards	
Quality mark	 (type:4/4X/12),  , EAC
Conformity	CQC, CE
General ordering information	
EAN13 code	8015747005876
Tariff number	85369095
Packaging Information	
Sub-packaging weight	0,92 kg
Sub-packaging description	Plastic packaging
Sub-packaging quantity	5 Pcs
Sub-packaging EAN barcode	8015747005883

Part number

CAF 10



Catalogue drawings

**CHO [CAO] CHV (CAV) - MHO [MAO]
MHV (MAV)**

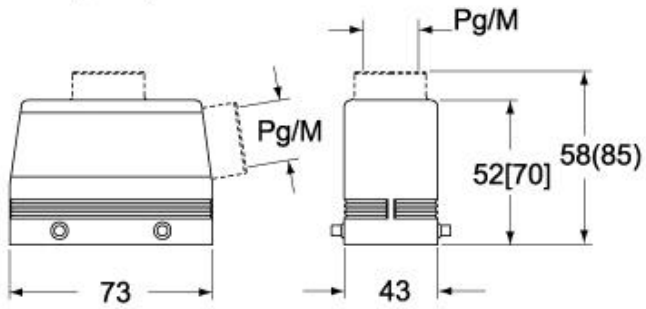

CAF - MAF/MFF

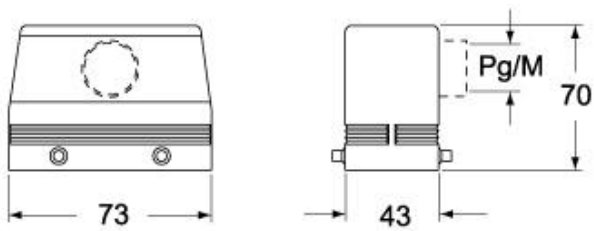

CHV G (CAV G) - MHV G (MAV G) - [MFV G]

